



AUSTRALIAN MADE

**CLIMATE**  
TECHNOLOGIES



**VULCAN**

YOUR COMFORT ZONE

# EXECUTIVE

## OPERATING INSTRUCTIONS

---

**RADIANT CONVECTIVE SPACE HEATER**  
**Flued Model HE 300M**

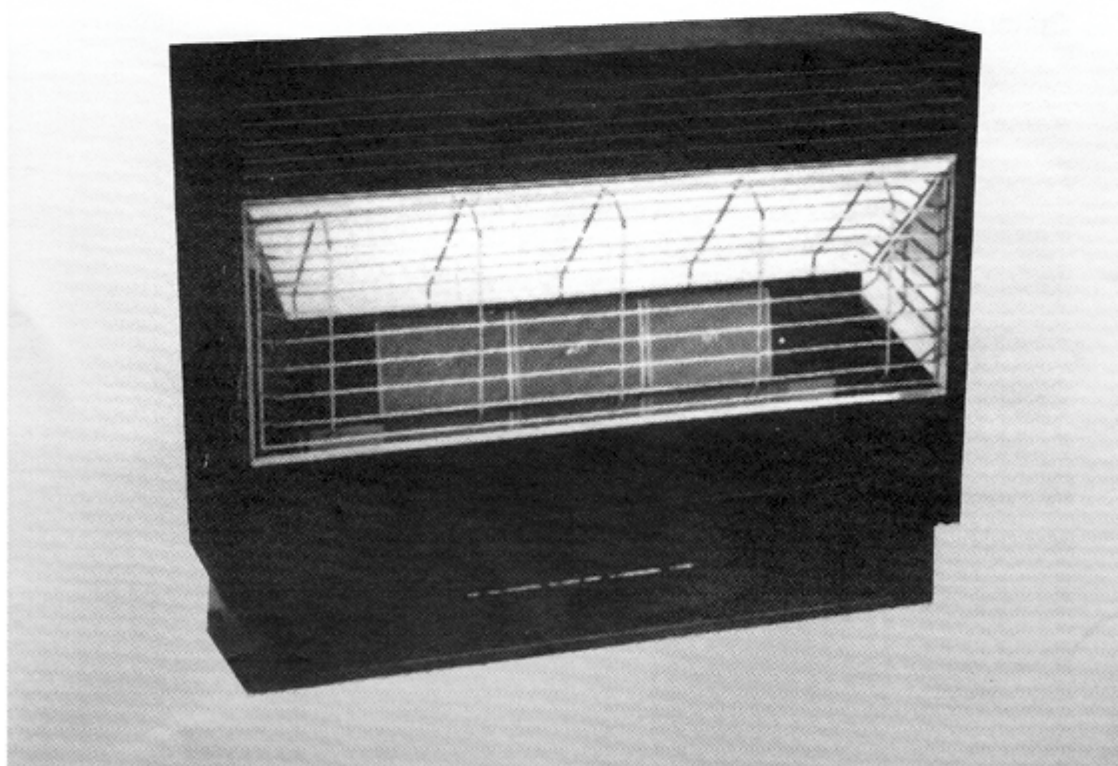

## CONGRATULATIONS ON YOUR CHOICE

We're delighted you've chosen a Vulcan to heat your home. It's a heater we're very proud of.

Designed and Made in Australia it embodies the latest advances in gas heating technology in a new stylish slimline cabinet.

Your Vulcan heater is backed by the resources of Climate Technologies Australia's most advanced manufacturer of a complete range of climate control products.

## INFORMATION

The information contained in the following pages has been prepared to ensure you enjoy trouble free operation of your Vulcan heater.

The Vulcan heater you have purchased is a flued radiant convective model with top mounted push-button controls and fan switch.

For safety, your Vulcan heater is fitted with a flame failure safety valve which will shut off the gas supply in the event of flame failure.

## CONTENTS

Congratulations.....	2
Information.....	2
Safety Precautions.....	3
Location of Controls.....	4
Starting your Vulcan Heater.....	4
Stopping.....	4
Heating Control.....	4
Cleaning.....	5
Problem/Remedy Chart.....	6
Warranty Statement.....	7
Warranty Detail.....	7
Service and Spare Parts.....	7
Proof of Purchase.....	7
Other Products.....	8

## SAFETY PRECAUTIONS

- Do not place articles on or against this appliance.
- Do not spray aerosols in the vicinity of this appliance while it is in operation.
- Do not use or store flammable materials near this appliance.
- Maintain clearances of 1500mm in front, 500mm above and 300mm to the left and right of the appliance.

**THE GUARD IS FITTED TO THE APPLIANCE TO REDUCE THE RISK OF FIRE OR INJURY FROM BURNS AND NO PART OF IT SHOULD BE PERMANENTLY REMOVED. FOR PROTECTION OF THE YOUNG OR THE INFIRM, A SECONDARY GUARD IS REQUIRED**

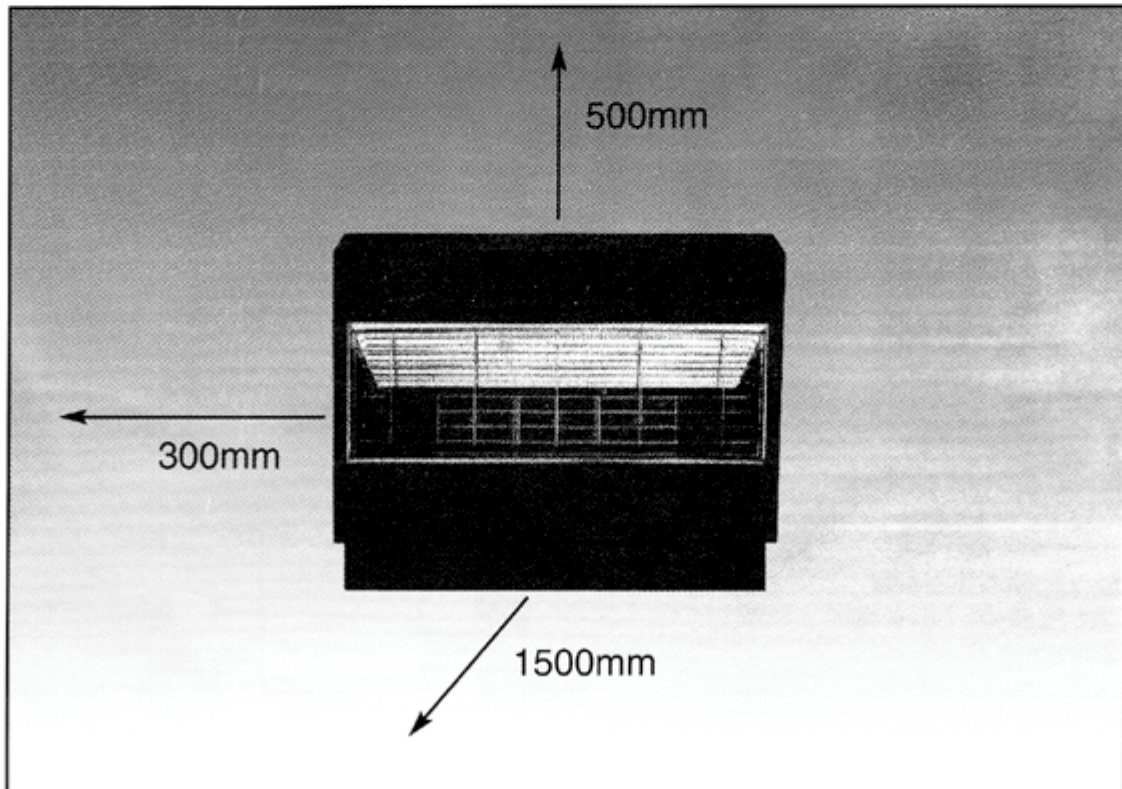

## LOCATION OF CONTROLS

All controls are mounted on the top of the heater.

### STARTING

1. Ensure gas supply is available and gas cock is turned on.
2. Connect power plug into a 220-240 volt 50Hz 10A power socket. Switch power on.
3. Push the START/LOW button down fully and hold in down positions.
4. Push the ON/OFF button down and hold until ignition occurs and the pilot lights. The pilot is located on the lower edge of the main burner, near the centre.
5. Hold the START/LOW button down fully for approximately 15 seconds after ignition.

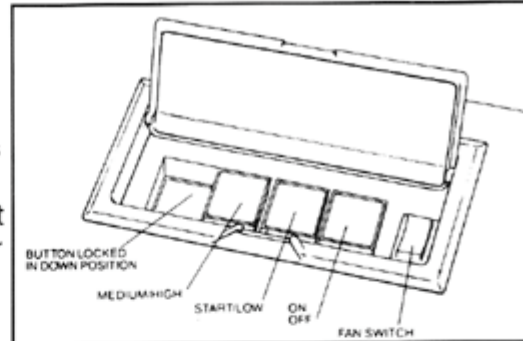

### NOTE ON STARTING

If the appliance has just been connected to the gas or not used for some time, it may not start the first time because of air in the gas line. It will then be necessary to repeat the starting procedure.

### STOPPING

Push to OFF button down firmly. NOTE: It is not necessary for all buttons to be in the up position when the heater is switched off.

### FAN







The fan has two operating speeds, HIGH and LOW which are selected at the fan switch. It is recommended that the fan be used when the burners are on.

In the event of power failure you heater will continue to operate safely without the fan. However it is recommended that the unit be operated on the medium setting to prevent heat build up in the cabinet.

## HEATING CONTROL

Three burner settings may be selected using the two left hand push buttons. The buttons have two operating positions each, up and down. Pushing a button fully down and releasing it changes its operating position.

### 3 BURNER MODELS

Setting	Burner operation	Controls	Fan
Low			Low
Medium			Low/High
High			High

## CLEANING

**OUTSIDE:** Turn heater off and isolate from electric power supply and clean all external parts with a soft damp cloth. **DO NOT USE SOLVENTS OR SCOURERS.**

**FAN.** The fan should be cleaned annually. Refer to service instructions in separate booklet.

**REFLECTOR.** Turn heater off and isolate from electric power supply. Lift wire dress guard adjacent to vertical pins in bottom edge. Lift pins clear of bottom reflector part and pull forwards, the bottom of the dress guard can now swing out. Clean the reflector with a soft damp cloth. Do not use scourers. Swing the dress guard shut and lift the pins back into the reflector holes.

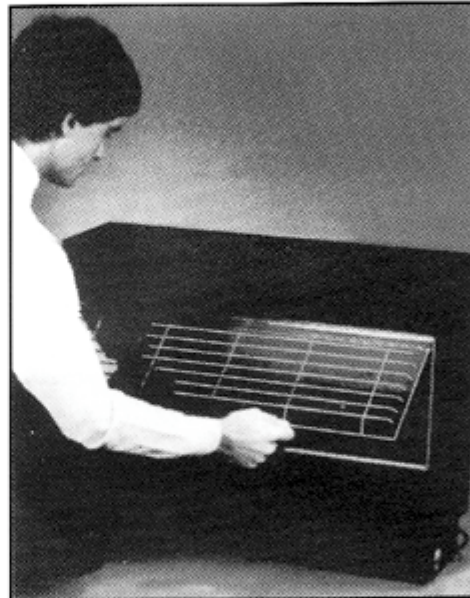
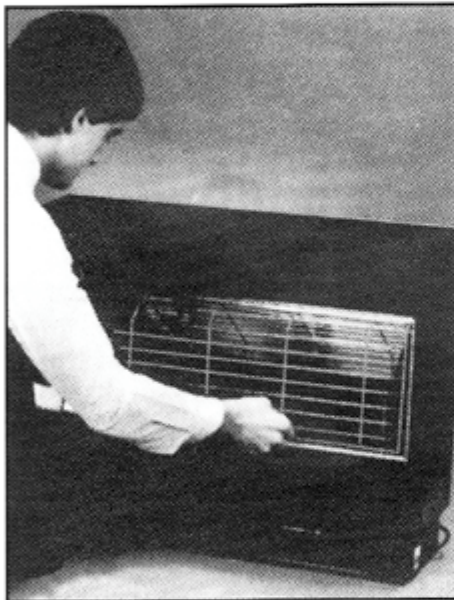

### IMPORTANT

This product, warranted by Climate Technologies (Vulcan), has undergone extensive testing at all stages of manufacture to ensure that it conforms to specification.

**Before requesting a service call check the following which are not covered by warranty:**

1. That all relevant services (electricity, gas, water) have been connected and turned on.
2. That the product has been installed correctly to Vulcan specifications.
3. That the product has been commissioned correctly by the installer.
4. That the operating instructions have been correctly followed.

**Should a Service Call be made by Vulcan or an approved Vulcan Service Agent that is not warranty related a service charge will apply.**

## PROBLEM REMEDY CHART

Before contacting your nearest VULCAN service centre, check the problem remedy chart closely. A service call may be unnecessary. If a service call is necessary, quote the model number indicated on the label under the control door.

CAUSE	PROBLEM									SOLUTION
	No ignition	Pilot will not stay on	Turns off by itself	Smells of gas	Burners not lighting	Long flames above burners	Fan will not run	Burners dull	Yellow pilot flame	
Power failure										Restore Power
Gas pressure incorrect										Contact Climate Technologies Service 131 052
Power off or plug out										Insert plug Switch on power
Gas line blocked										Contact Climate Technologies Service 131 052
Incorrect burner aeration										As above.
Spark system damaged										As above.
Air in gas line										Stop and restart until air clear.
Insufficient button force										Read starting instructions.
Not enough air										Switch heater off. Ventilate room. Contact Climate Technologies Service 131 052



# VULCAN

## WARRANTY STATEMENT

In the event that your Vulcan appliance is or becomes defective in the warranty period due to faulty materials, components or workmanship, the Trade Practices Act of 1974 and similar laws in your state give you the right under certain circumstances to have it made good.

In addition, Climate Technologies makes the following promise - WE WILL REPAIR OR IF NECESSARY REPLACE A DEFECTIVE VULCAN APPLIANCE ON THE FOLLOWING TERMS AND CONDITIONS.

### WARRANTY PERIOD – EXECUTIVE HEATERS

	LABOUR	PARTS
Heat Exchanger (HE Models)	1 year from date of purchase	5 years from date of purchase + 5 years pro rata
Fan	1 year from date of purchase	2 years from date of purchase
Other parts	1 year from date of purchase	1 year from date of purchase

### WARRANTY ON REPLACEMENT PARTS

Parts replaced under warranty are warranted for the balance of their original warranty period

**For Metro Service Only Ring The Number Below**  
**South Australia 08 8307 5230**  
**NSW/ACT 02 6953 5968**  
**Western Australia 08 9454 1000**  
**Victoria 03 8795 2456**

### CONDITIONS AND EXCLUSIONS

Repair and replacement work will be carried out free or on the basis shown above subject to proof of purchase and purchase date but the following is not covered:

- Travelling costs incurred by Climate Technologies Service personnel or Service Agent beyond 25km from Climate Technologies authorised Service Depot and/or the cost of transporting and insuring the appliance between the nearest Climate Technologies or Agent's Service Depot and its normal locations. These costs must be met by the owner.
- The cost of the work or a service call where there is nothing wrong with the appliance or where the defective operation of the appliance is due to failure of gas or electricity or water supply, to incorrect plumbing or installation not in accordance with instructions and/or applicable local regulations, to defects caused by incorrect application or abuse of the appliance, or to damage caused by any unauthorised person attempting to repair the appliance.
- Subject to any statutory provisions to the contrary, claims for damage to furniture, carpets, walls, ceilings, foundations or any other consequential loss either direct or indirect resulting from a faulty appliance.
- Repairs to an appliance incorrectly used or accidentally damaged.

## EXECUTIVE WARRANTY DETAIL

Please retain this copy for your personal record.

NAME .....

ADDRESS .....

.....POSTCODE.....

MODEL No. ....SERIAL No.....

DATE OF PURCHASE.....

PURCHASED FROM .....

INSTALLER (Name).....

### PROOF OF PURCHASE

**NOTE: Please produce the fully completed warranty details at the request of the Serviceman or Installer.**



It is important that you record the name of the Dealer or Gas utility from whom you purchased your heater and the name of the Installer, who is responsible for the correct installation and start-up of this heater, and demonstrating the correct method of operation.

## WORTH CONSIDERING

As experts in home comfort products, Climate Technologies has a lot to offer the Australian household.

## COOLEST THING ON WHEELS

The new BONAIRE ULTRACOOLER is a stylish portable air cooler which can be wheeled from room to room to provide cool comfort wherever you are. With its "Sleepeasy" fan it will keep you comfortable during the hottest days and nights.

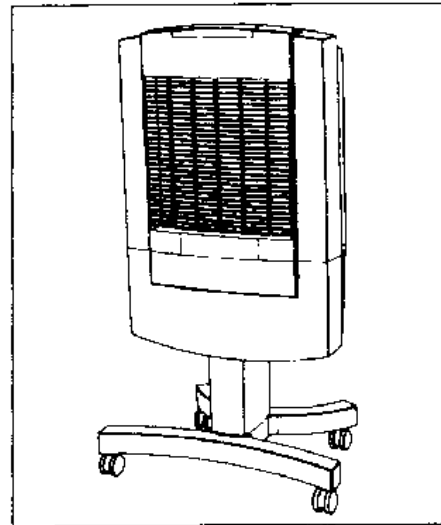

## FRESH AIR COOLING

The new BONAIRE INTEGRA Ducted Evaporative Air-Conditioning Systems use only water to cool the air. No ozone depleting CFC gases at all. With "Coolstart" for instantly cool air and the "Superquiet" Axial fan for quiet performance, your home will become a paradise of cool comfort.

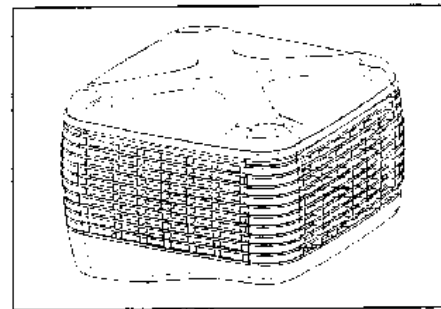

## VULCAN CENTRAL HEATING

The VULCAN HIGH EFFICIENCY CENTRAL HEATER is a revolutionary ducted heating system which will warm you from any room in the house. This High Efficiency gas ducted heater is the most effective and cost efficient way to heat your entire home, all at the touch of your fingertips with the remote Comfort Control.

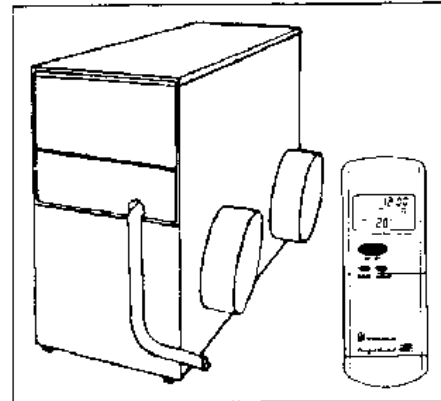

DESIGNED & MANUFACTURED BY....

**CLIMATE**  
TECHNOLOGIES

ACN 13 001 418 042

26 Nylex Avenue, Salisbury, South Australia 5108

In the interests of continued product improvement, Climate Technologies reserves the right to alter specifications without notice.

 **VULCAN**  
YOUR COMFORT ZONE

© Text and Illustration Copyright, Climate Technologies 2001  
All rights reserved, no part of this document may be reproduced or transmitted in any form or by means, electronic or mechanical, including photocopying, recording or by any and information storage and retrieval system, without prior permission in writing from Climate Technologies.

  
AUSTRALIAN MADE